

■ Dimensions

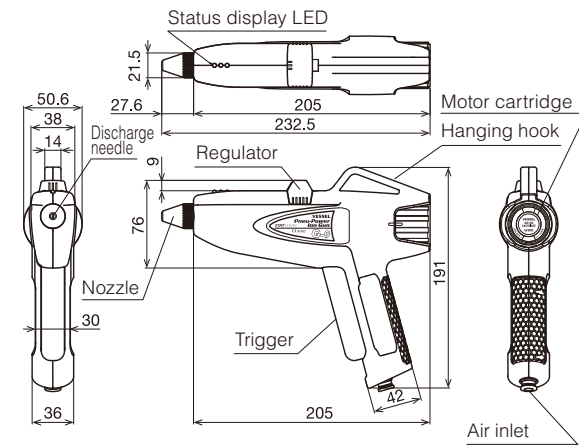

■ Specifications

Model No.	G-9
Type	High voltage applied ionizer
Structure	Direct-coupled
High voltage power source	Coiled transformer
Ionizing method	High-frequency AC corona discharge
Applied voltage / Frequency	8kVAC p-p ( ± 5% ) / 32kHz (Typ.)
Air supply	φ8mm tube applied, One-touch joint
Operating fluid / Input pressure	Clean dry air / 0.4~0.6MPa (Rated 0.5MPa)
Air volume	210L/min (0.5MPa)
Decay time	± 1000V→± 100V:1sec. or less(0.5MPa, 210L/min, 150mm)
Ion balance	± 30V (0.5MPa, 210L/min, 150mm)
Noise	74.6dBA (0.5MPa, 210L/min, 1m)
Protective circuit	High-voltage short-circuit detection circuit / Automatic shutdown / Automatic recovery
Operating temp. / humidity	0~+45°C / 10~90%RH(No freezing or dew condensation)
Storage temp. / humidity	30~+50°C / 10~90%RH(No freezing or dew condensation)
Material	Body, Nozzle, Motor cartridge: Polycarbonate / Discharge needle: Tungsten / High flow nozzle: PC/ABS
Dimensions	H191 x W232.5 x D50.6mm
Weight	Approx. 470g
Place of use	Indoor
Accessories	Instruction manual, High flow nozzle G-9HFN

■ Options

- Straight silent nozzle BB-ZSN (EDP No.621708)
- Silent nozzle G-9WN (EDP No.806151)
- Plug with urethane tube (EDP No.806148)

■ Replacement parts

- Needle electrode GN-H (EDP No.806124)
- Needle electrode replacement screwdriver G-7DR (EDP No.806061)
- Motor cartridge G-9MC (EDP No.806147)
- High flow nozzle G-9HFN (EDP No.806154)

■ G-9(Standard nozzle)

Width	Distance	50 mm	100 mm	150 mm	200 mm	250 mm	300 mm
150 mm	>10	>10	>10	>10	6.08	>10	1.71
100 mm	>10	1.10	0.43	0.54	>10	0.59	
50 mm	0.33	0.34	0.35	0.40	0.66	0.50	
0 mm	0.32	0.33	0.35	0.41	0.46	0.59	
50 mm	0.35	0.36	0.56	0.63	0.43	1.36	
100 mm	>10	>10	>10	>10	0.54	>10	
150 mm	>10	>10	>10	>10	2.99	>10	

■ G-9(High flow nozzle G-9HFN)

Width	Distance	50 mm	100 mm	150 mm	200 mm	250 mm	300 mm
150 mm	>10	>10	>10	>10	>10	>10	>10
100 mm	>10	8.56	0.65	3.16	0.95	0.78	
50 mm	0.36	0.33	0.36	0.35	0.40	0.45	
0 mm	0.38	0.35	0.34	0.35	0.39	0.42	
50 mm	0.36	0.34	0.35	0.35	0.42	0.46	
100 mm	7.60	0.80	2.70	0.88	0.64	0.77	
150 mm	>10	>10	>10	>10	>10	>10	

※Decay time (sec.): ±1000V→±100V, Air pressure: 0.5MPa, Air volume: 210L/min  
 ※Charged plate monitor: Trek 158A 150mm SQ., 20pF, 23°C, 50%Rh

■ Discharging area

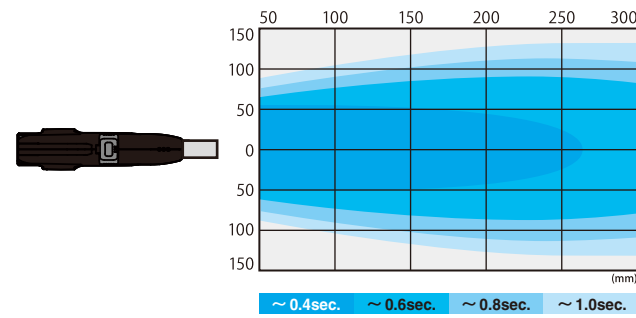
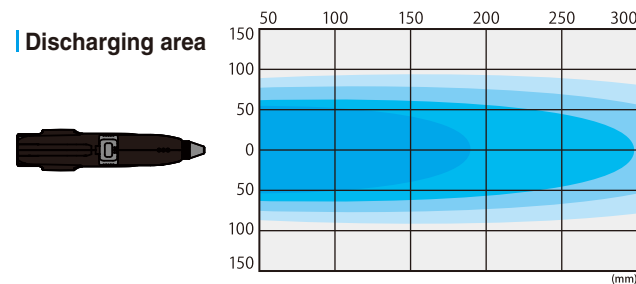

■ Air volume, Noise, Blow-off power

Measured data	Air volume(L/min)	Noise(dBA)	Blow-off power(N/m <sup>2</sup> )	with G-9HFN		
				Air volume	Noise	Blow-off power
Air pressure	Lamp: Green	1000 mm	150 mm			
0.6 MPa	240	77.4	49	250	89.0	66
0.5 MPa	211	74.6	37	211	87.3	51
0.4 MPa	186	76.2	30	284	84.3	38

●Drop durability test: 180 cm free fall (concrete surface) that exceeds JIS standards; Confirmed that the product is not damaged even after 10 trials and that it operates without problem.  
 ●The noise was measured at 1,000mm. ●the blow-off power was measured at 150mm.

⚠ Warning

- For your safety, read the instruction manual carefully before using this product.
- Never use this product in hazardous area requiring explosion proof measures.
- A high voltage is applied on this product. Make sure that water, oil, etc., do not come in contact.
- Avoid condensation as it can result in electric shock or product damage.
- Keep away metal objects such as tools or wires, or body parts such as fingers, hands, or face from the discharge needle due to applied high voltage.

VESSEL Co., Inc.

17-25, Fukae-Kita 2-chome, Higashinari-ku, Osaka 537-0001 JAPAN  
 Tel : +81(0)6 6976 7778 Fax : +81(0)6 6972 9441  
 E-mail : export@vessel.co.jp URL : www.vessel.co.jp/english

VESSEL EUROPE

contact@vessel-europe.com  
 www.vessel-europe.com

●For improvements, the product specifications, size, and others may be subject to change without prior notice. 23071823.10



**PATENTED!**  
 Power generation without external power supply or cable.  
 Removal of static electricity and dust.

STAT·CLEAN series

Pneu-Power Ion Gun No.G-9 EDP No.621670



**NEW!!**

**High Flow Nozzle is now enclosed!**

By using this new nozzle, **blowing performance is dramatically improved!**





# Advantages of Pneu-Power Ion Gun

**1** Cable troubles are prevented!  
**No repair due to cable breakage.**

**2** Safe because the legs don't get caught!  
**The foot space is widely secured.**

**3** Neither outlet nor high voltage cable is required.  
**No separate high voltage power unit.**

"Self-power generating ionizing gun". No need for electric wiring.  
**Eliminate static electricity only with compressed air!**

## Superior Ionizing Performance + Ion Balance

Decay time: 1 sec. or less  
 Ion balance: within  $\pm 30V$   
 (1000V  $\rightarrow$  100V  $\cdot$  20pf CPM  $\cdot$  0.5MPa  $\cdot$  150mm)

## High Flow Discharge

High Flow Nozzle for improved blowing performance. Suitable for static elimination and dust removal from automobile bumper paint, sheet metal, and large resin molded products.



**Replaceable**

High Flow Nozzle (enclosed)

## Comply with

**RoHS** (10 substances)

## Applications



Static elimination and dust removal...

- Before painting process of large parts; (for automotive, furniture, music instruments, and so on.)
- Before bringing into a clean room parts which are just taken out of the package;
- of Big size film, sheet material, and so on.

## Convenient for air volume adjustment. Regulator & Adjustment Lamp

Air flow can be visually adjusted. A red light indicates too much air and a yellow light indicates insufficient air. Adjust the air flow so that the green light comes on.

**Air and ions that are blown out.**

## Prevention of breakage. Hanging Hook + Metal Fitting

There is reinforced metal fitting in the hanging part.



**Turbine generates electricity.**

## Power generation by air. Motor Cartridge (Replaceable)

Convert compressed air to electricity. Replacement reference every 1 or 2 years.

## Stable ion generation. Coiled High Voltage Transformer

Transformer that can increase voltage and generate ions in a stable manner.

**Air is diverged into 2 routes: for power generation and dust removal respectively.**

**Just connect the air tube to use. ( $\phi 8 \times \phi 5$  air tube)**

## Easy maintenance. Replaceable Needle Electrode

Air passes through the electrode. Wipe with a cotton swab for maintenance. (Approx. 1 year for replacement)

## No extra force. Trigger

Light force is required to activate the air supply.

## User's voice



- Previously, there were cables that required wiring for power cables, but it is no longer necessary.
- Since air hoses are present in every process, this product can be used immediately at any location.
- There used to be a lot of repairs due to broken wires, but after using this product, there is no more need for repairs.
- In the pre-painting process, the air hose can be used anywhere as long as there is only air wiring. No power source is needed.
- I no longer have to worry about cables getting tangled up and falling over.